

# DURATEX™

BASE SHEET



Build it better with **BGC**

**BGC**

Fibre Cement

## HISTORY & MISSION

BGC FIBRE CEMENT AND PLASTERBOARD IS A PROUD AUSTRALIAN OWNED MANUFACTURER OF FIBRE CEMENT AND PLASTERBOARD PRODUCTS.



BGC has state-of-the-art manufacturing facilities in Perth and distribution centres in all states of Australia and in New Zealand.

Our distribution network ensures that our entire product range is readily available in all states of Australia and in New Zealand.

BGC has a team of technical specialists that can assist with all specification and design information to help ensure that you always **'build it better with BGC'**.

### BGC HAS INTERESTS IN

- / Residential and commercial building
- / Building and construction products
- / Contract mining
- / Civil engineering construction and maintenance
- / Quarrying
- / Road transport
- / Property ownership and management
- / Insurance

Our mission at BGC is simple – we want to ensure that people can always **'build it better with BGC'**.

In keeping with our mission, we are constantly assessing and improving our products to ensure that we always provide cost effective, high quality and easy-to-use products to the market.



# CONTENTS



5 // PRODUCT DESCRIPTION		
5 // PRODUCT INFORMATION		
5 // SHEET SIZES AND MASS		
6 // FIRE RESISTANCE		
6 // HANDLING AND STORAGE		
6 // HEALTH AND SAFETY		
6 // SHEET CUTTING AND DRILLING		
6 // THERMAL BRIDGING		
7 // SHEET LAYOUT		
7 // FIXING INSTRUCTIONS		
7 // FRAMING		
7 // FASTENERS		
	CONSTRUCTION DETAILS	
	8 // SHEET FIXING	
	9 // JOINT DETAILS	
	9 // CONTROL JOINTS	
	9 // RELIEF JOINTS	
	10 // GROUND CLEARANCE	
	11 // WINDOWS AND DOORS	
	12 // JOINT AND COATING SYSTEMS	
	13-14 // BRACING	
		15 // DURATEX™ COMMERCIAL 9MM
		16 // FRAMING
		16 // FIXING
		17 // CONTROL JOINTS
		17 // WARRANTY
		18 // BUSHFIRE AND BOUNDARY WALL

# DURATEX™

BASE SHEET



A TOUGH, DURABLE, WATERPROOF EXTERNAL CLADDING SYSTEM, BGC DURATEX™ PROVIDES A SOLID SUBSTRATE FOR APPLIED HIGH BUILD DECORATIVE FINISHES WHEN COMBINED WITH PROPRIETARY JOINTING AND COATING SYSTEMS.

TOUGH, DURABLE, WATERPROOF AND FIRE-RESISTANT, DURATEX™ IS GREAT FOR LIGHTWEIGHT CONSTRUCTION AND FEATURES A FACTORY-APPLIED BLUE TINT TO HELP YOUR IDENTIFICATION.

#### DURATEX™

- // Specify for residential and commercial applications
- // Accepts wide range of textured coatings
- // Complies with AS3959:2009 – Construction of buildings in bushfire prone areas (7.5mm: BAL29; 9.0mm: BAL40)



## PRODUCT DESCRIPTION

Duratex™ is a fibre cement sheet that provides a solid substrate for applied decorative finishes.

Duratex™ sheets when combined with a proprietary jointing and coating system provide a tough, durable, waterproof wall cladding system that is immune to water damage, is fire resistant and is ideal for lightweight construction. It accepts a wide range of textured coatings and colours.

Incorporating high-density polystyrene profiles bonded to the Duratex™ can further enhance the architectural effect.

## ENERGY EFFICIENCY CONSIDERATIONS

Energy efficiency requirements have been introduced into the BCA for both commercial and residential buildings. Thermal heat transfer into and out of the building envelope can affect the running cost of the building and careful consideration of thermal heat transfer needs to be addressed by the architects, engineers and building designers. Thermal bridging through steel framing will diminish the total R-Value; thermal conductance of the wall. Thermal breaks are required for steel framed buildings and should be installed between the lightweight steel CFS stud and/or top hat sections and the Duratex™ cladding.

Thermal breaks should have a minimum R-Value of 0.2 or less.

## PRODUCT INFORMATION

Duratex™ is manufactured to conform to the requirements of AS2908.2 Cellulose-Cement Products and is classified as Type A Category 2 sheet for external use.

## DEEMED TO COMPLY

Duratex™ is approved by the Northern Territory Building Advisory Committee for Darwin Cyclonic Areas as detailed in the Deemed to Comply Manual drawings M/222/3 and M/222/4.

## QUALITY SYSTEMS

BGC Fibre Cement manufactures Duratex™ under the rigorous Quality Management System of the International Standard ISO 9002:1994 and is the holder of Licence Agreement number QEC2955/13.

## SHEET SIZES

THICKNESS (mm)	MASS kg/m <sup>2</sup>	WIDTH (mm)	LENGTH (mm)				
			1800	2400	2440	2725	3000
7.5	10.9	900			✓	✓	✓
		1200	✓		✓	✓	
9	13	1200		✓			✓

Weights are based on Equilibrium Moisture Content.

## SHEET TOLERANCES

Duratex™ complies with the requirements of AS2908.2

## FIRE RESISTANCE

Duratex™ has been tested for and passed the Early Fire Hazard Property criteria in compliance with AS/NZS 1530.3 and AS/NZS 3837 and is deemed a Group 1 Material in accordance with the BCA, Volume 1. Specification A2.4; Fire Hazard Properties. AS/NZS 1530.3; Early Fire Hazard Properties.

This report deemed the following Early Fire Hazard Properties

// Ignition Index	0
// Spread of Flame Index	0
// Heat Evolved Index	0
// Smoke Developed Index	0-1

## HANDLING & STORAGE

Duratex™ must be stacked flat, up off the ground and supported on equally spaced (max 300mm) level gluts.

The sheets must be kept dry, preferably by being stored inside a building. When stored outdoors they must be protected from the weather.

Care should be taken to avoid damage to the ends, edges and surfaces.

Sheets must be dry prior to being fixed, jointed or coated. Sheets must be carried on edge.

## HEALTH & SAFETY

Duratex™ is manufactured from cellulose fibre, finely ground sand, Portland cement and additives. As manufactured, the product will not release airborne dust but, during drilling, cutting and sanding operations cellulose fibres, silica and calcium silicate dust may be released.

Breathing in fine silica dust is hazardous, prolonged exposure (usually over several years) may cause bronchitis, silicosis or cancer.

## AVOID DUST INHALATION

When cutting sheets, work in a well-ventilated area and use the methods recommended in this literature to minimise dust generation. If using power tools wear an approved (P1 or P2) dust mask and safety glasses.

These precautions are not necessary when stacking, unloading or handling fibre cement products.

For further information or a Material Safety Data Sheet contact the nearest BGC Fibre Cement Sales Office or go to [www.bgcinnovadesign.com.au](http://www.bgcinnovadesign.com.au)

## SHEET CUTTING & DRILLING

Duratex™ may be cut to size on site. If using power tools for cutting, drilling or sanding they must be fitted with appropriate dust collection devices or alternatively an approved (P1 or P2) dust mask and safety glasses shall be worn.

It is recommended that work always be carried out in a well-ventilated location.

The most suitable cutting methods are:

### // SCORE AND SNAP

Score the sheet face 4 or 5 times with a 'score and snap' knife. Support the scored edge and snap the sheet upward for a clean break.

### // HAND GUILLOTINE

Cut on the off-cut side of the line to allow for the blade thickness.

### // DRILLING

Use normal high-speed drill bits. Do not use the drill's hammer function. For small round holes, the use of a hole-saw is recommended.

### // DURABLADE

180mm diameter. This unique cutting blade is ideal for cutting fibre cement. It can be fitted to a 185mm circular saw. Please ensure safe working practices when using.



For small rectangular or circular penetrations, drill a series of small holes around the perimeter of the cut out. Tap out the waste piece from the sheet face while supporting the underside of the opening to avoid damage. Clean rough edges with a rasp.

Large rectangular openings are formed by deeply scoring the perimeter of the opening. Next, form a hole in the centre of the opening (refer method above) then saw cut from the hole to the corners of the opening. Snap out the four triangular segments. Clean rough edges with a rasp.

## THERMAL BRIDGING

Thermal breaks are required for steel framed buildings in walls enclosing habitable and/or useable spaces. Careful consideration of thermal heat transfer and the position of thermal breaks need to be addressed by the architects, engineers and building designers.

Balustrades, parapets and other non enclosing wall elements may not require thermal bridging, except where the possibility of high thermal heat transfer exists through the steel CFS sections to the main structural steel element of the building.

Thermal breaks should be installed between the Duratex™ and the steel framing.

Thermal bridging is to be no less than R 0.2.

For further information refer to section of the National Construction Code Series/BCA.

## SHEET LAYOUT

Duratex™ must be joined over a stud and the ends of the sheet supported by the top/bottom plate. Butt sheets tightly together except where control joints are employed or at an internal corner.

On internal corners leave a 3-5mm gap for polyurethane sealant. (Refer Figure 5)

At external corners, the sheet joint must finish flush - do not leave any gap. (Refer Figure 6)

Vertical fixing of sheets is recommended. When fixing more than one sheet high, vertical joints must be in line.

Framing studs should be spaced at maximum centres of 600mm so they will conform to the sheet widths.

Horizontal fixing of Duratex™ is permissible only where the cladding height does not exceed the sheet width, ie 1200mm.

## FIXING INSTRUCTIONS

The success of any jointing system is very much dependent upon the correct construction of the framing, the fixing of the Duratex™, and the application of the jointing materials.

Duratex™ sheets must be dry before fixing to the framing structure. Sheet cuts, which are to be flush jointed, must be recessed on site (see Figure 1). The Hitachi 'Easy Bevel' (Model EB100) is specifically designed for this purpose.

**FIGURE 1 //**  
DURATEX™ ON SITE RECESSING

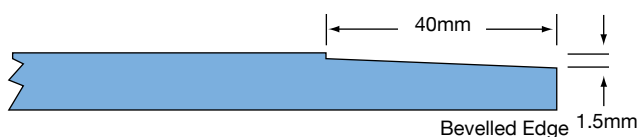

## CONSTRUCTION DETAILS - FRAMING

Duratex™ is suitable for use with both timber and lightweight steel framing.

## GENERAL

- // Framing must be constructed to comply with the Building Code of Australia.
- // The framing must be set to a true plane to ensure a straight finish to the wall.
- // Studs must be spaced at a maximum of 600mm centres.
- // Noggings must be spaced at a maximum of 1350mm centres. See Figure 2.
- // Duratex™ wall sheets must not be joined off the framing.

## TIMBER FRAMING

Timber framing must comply with AS 1684.2 & .3 1999 Residential Timber - Framed Construction.

Duratex™ must not be fixed to wet framing. It is strongly recommended that kiln dried timber is used for framing.

If sheets are fixed to 'wet' framing, problems may occur at a later date due to excessive timber shrinkage.

## METAL FRAMING

Metal framing must comply with AS 3623 - 1993 Domestic Metal Framing.

Duratex™ may be fixed directly to lightweight metal framing. The metal framing must not exceed 1.6 mm in thickness.

If Duratex™ is used with rigid steel framing, it must be battened out with either timber or lightweight steel battens prior to fixing.

Timber battens must have a minimum thickness of 40mm to allow adequate nail penetration. Battens supporting sheet joints must have a minimum actual face width of 45mm.

## FASTENERS

For general applications Duratex™ sheets are fixed to timber framing using 30 x 2.8mm Galvanised Flat-Head Nails.

30 x 2.8mm Galvanised Flat Head Nail



For fixing Duratex™ sheets to metal frames, use

No.8 x 20mm Galvanised Self-Embedding Head Screw

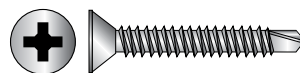

## SHEET FIXING

Duratex™ sheets are to be installed vertically and fixing to be spaced at a maximum of 200mm centres.

For details on bracing see pages 13 & 14 where fasteners are at 150mm around the perimeter and 200mm centres in the body of the sheet.

Do not place fixings closer than 12mm from sheet edges, or closer than 50mm from sheet corners.

The sheet must be held firmly against the framing when fixing to ensure breakout does not occur on the back.

## SARKING

In wall cladding applications, the installation of a vapour permeable sarking between Duratex™ and the framing is recommended.

Under windy conditions the building's internal pressure will generally be less than the external air pressure, this will tend to draw water through flashing and seals if sarking is not used.

Use of a reflective vapour permeable sarking will enhance the insulation properties of the cladding system.

FIGURE 2 //  
SHEET FIXING

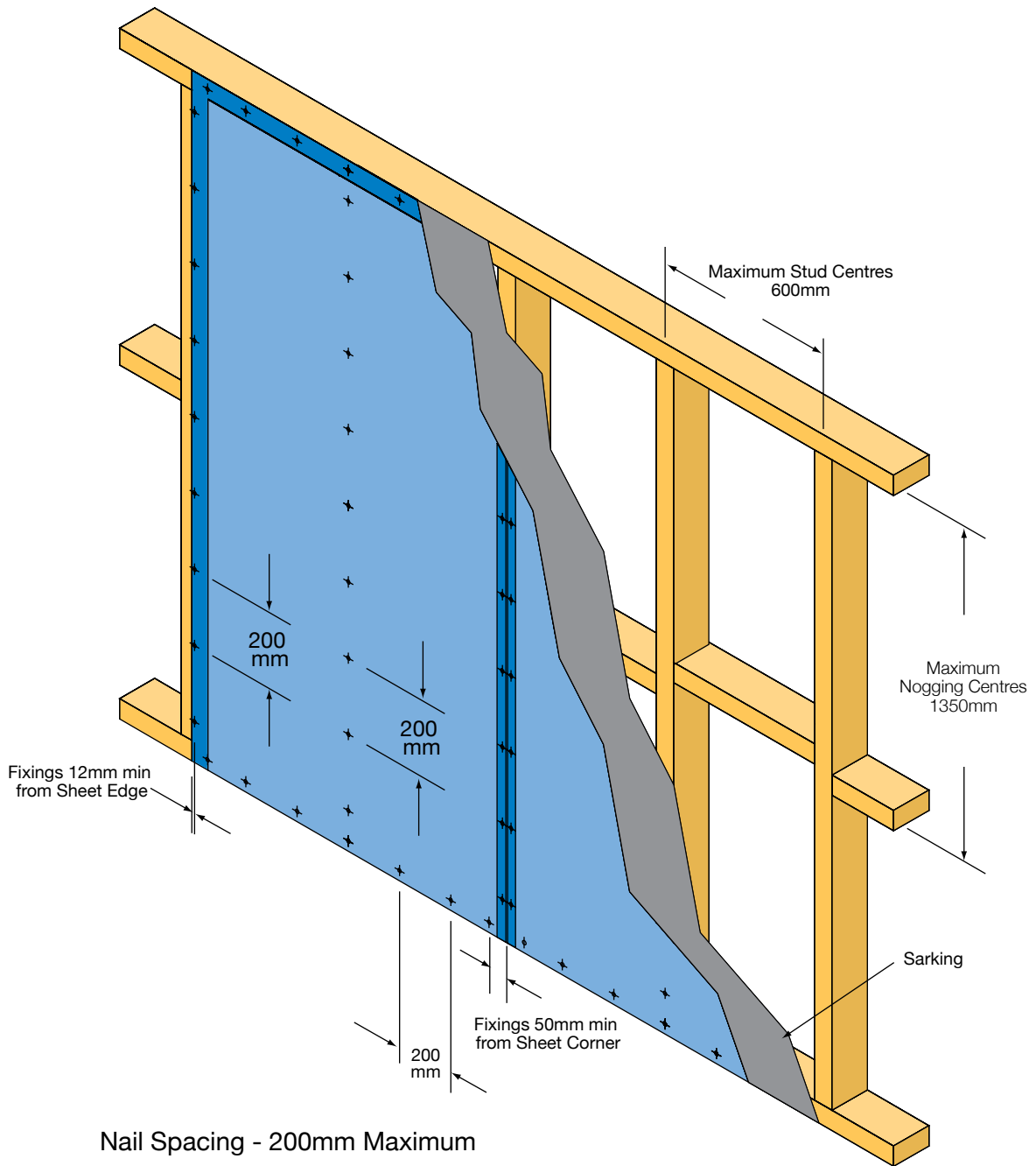



# IRREGULAR WALL SURFACES

**FIGURE 3 //**  
JOINT DETAILS TIMBER FRAME CONSTRUCTION

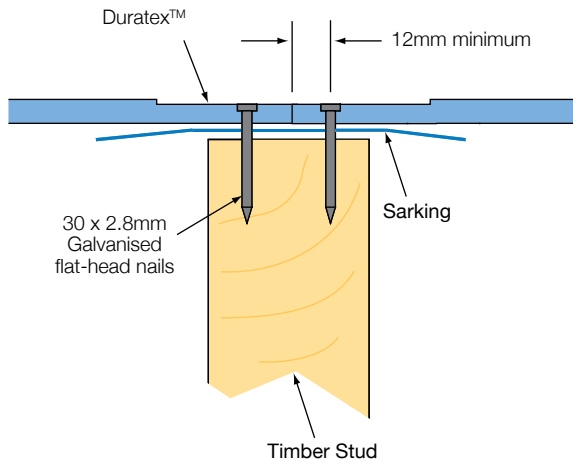

**FIGURE 6 //**  
EXTERNAL CORNER JOINT

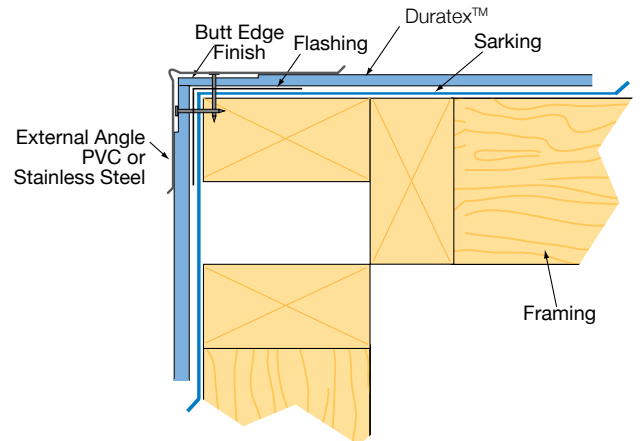

**FIGURE 4 //**  
JOINT DETAILS STEEL FRAME CONSTRUCTION

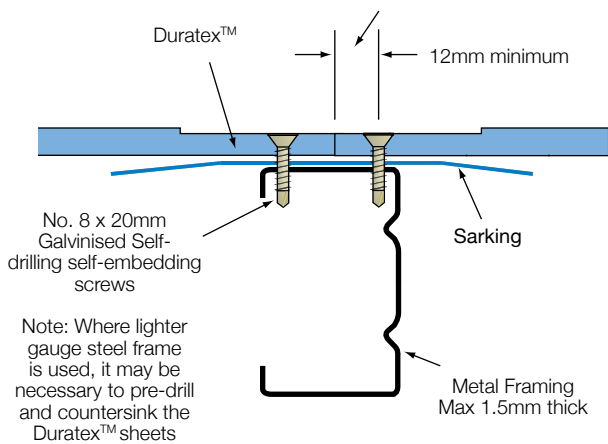

## CONTROL JOINTS

### VERTICAL RELIEF JOINTS

Where a wall is longer than 5400mm a vertical relief joint must be incorporated in the wall structure at no more than 5400mm (see Figure 7) Location of control joints should be considered prior to the installation of the Duratex™ sheets. Control Joints require a 6mm gap between sheets and caulked with polyurethane. In walls exposed to radiant sun and high temperature control joints at 3600mm are recommended.

### STRUCTURAL JOINTS

Structural movement joints incorporating the frame must be provided when required by the designer. The frame must have total separation including the top and bottom plates (see Figure 8).

**FIGURE 7 //**  
VERTICAL RELIEF JOINT

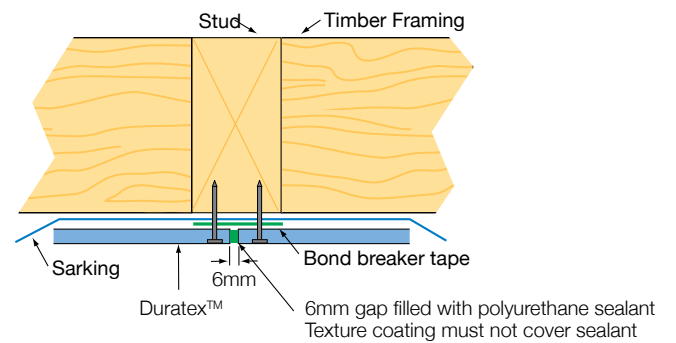

**FIGURE 5 //**  
INTERNAL CORNER JOINT

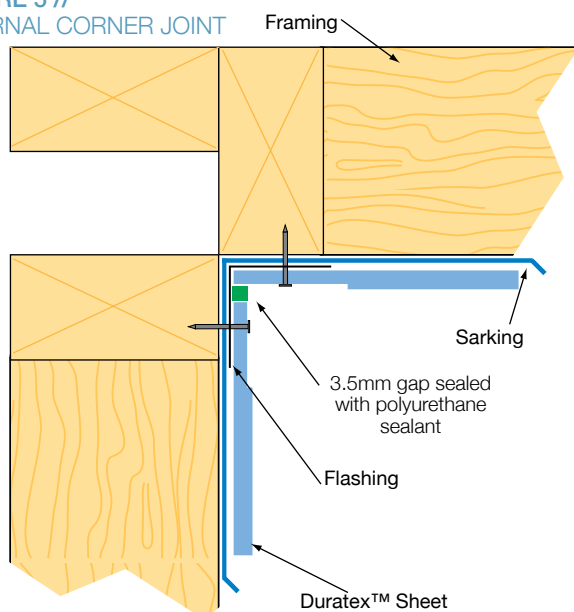

**FIGURE 8 //**  
VERTICAL CONTROL JOINT

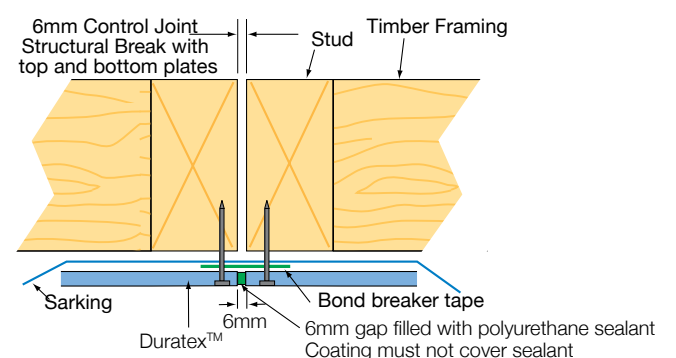

## HORIZONTAL RELIEF JOINTS

Horizontal Relief Joints must be provided if the wall height exceeds 3600mm or wherever floor joists occur. (This is imperative if non-kiln dried timber floor joists or framing are used).

Alternatives to this relief joint are:

- // To use a horizontal "Z" flashing strip.
- // Let the floor joists overhang the top plates of the lower floor to create a sealed sheet overlap.

**FIGURE 9 //**  
TYPICAL HORIZONTAL RELIEF JOINT

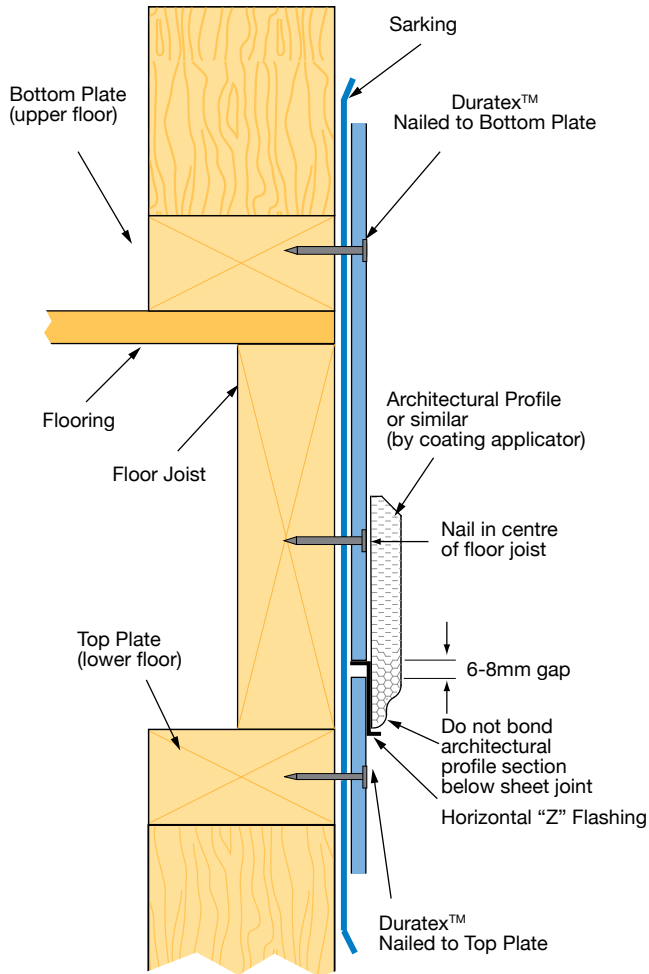

## HORIZONTAL RELIEF JOINTS

Duratex™ must not be applied to nominal horizontal surfaces such as the tops of parapets, sills, decking upstands, etc. These surfaces must be sloped a minimum of 15° to the horizontal for light-texture finishes, or a minimum of 30° for heavy-texture finishes. The alternative is to install a fully sealed and waterproof membrane system immediately under the cladding on the horizontal surface or install a capping.

## WALL ABUTMENT

Control Joints must be employed when an addition is constructed onto an existing building or when a masonry wall adjoins a timber or steel framed construction.

Control Joints should be constructed using 9mm diameter backing rod and polyurethane sealant on abutment to existing masonry walls.

**FIGURE 10 //**

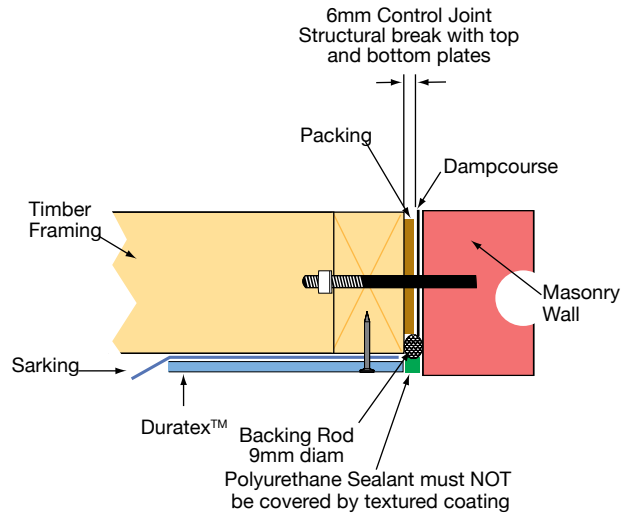

## GROUND CLEARANCE

Duratex™ must not be used in situations where it will be below ground or where it will be buried in the ground. The ground clearances as set out in Figure 11 must be adhered to at all times.

**FIGURE 11 //**  
GROUND CLEARANCE

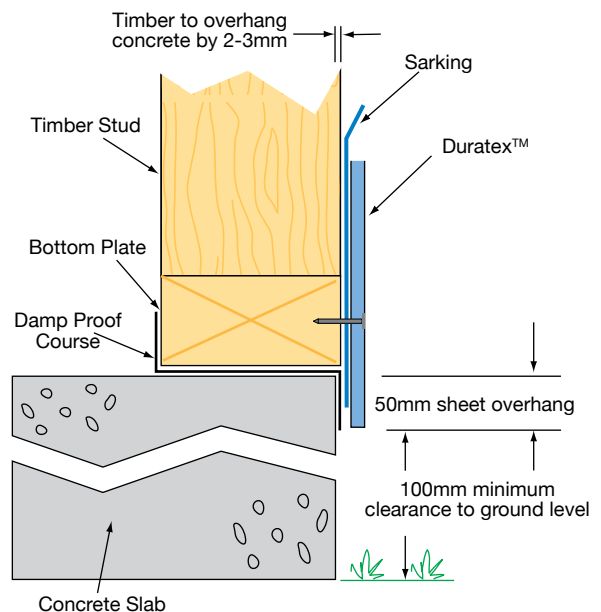

**FIGURE 12 //**  
TYPICAL WINDOW FRAME WEATHER PROOFING  
LINTEL DETAILS

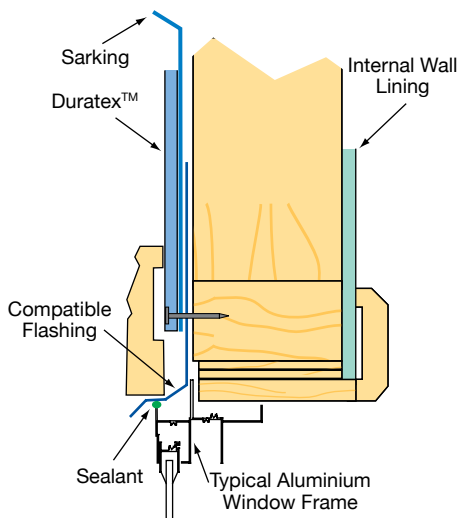

**FIGURE 12 //**  
TYPICAL WINDOW FRAME WEATHER PROOFING  
JAMB DETAILS

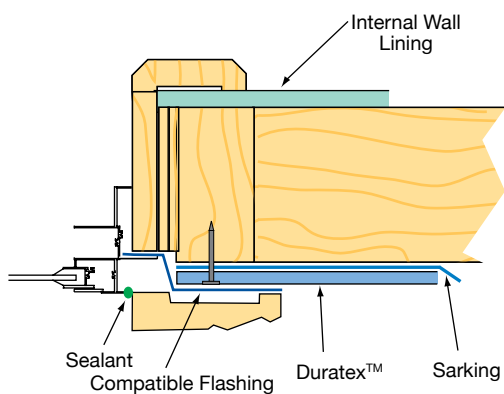

**FIGURE 12 //**  
TYPICAL WINDOW FRAME WEATHER PROOFING  
SILL DETAILS

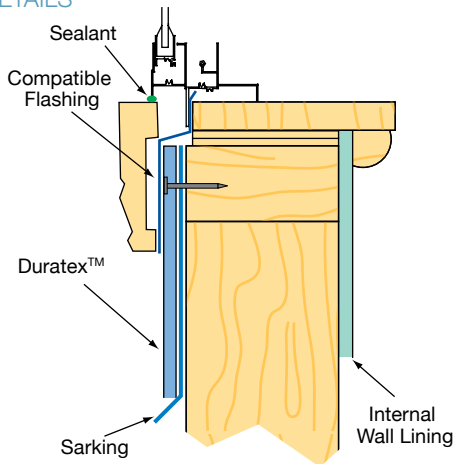

To reduce the incidence of cracks appearing in the jointing, flush jointed sheets should be cut in (200mm minimum) around window and door openings as depicted in Figure 13 .

If a sheet joint must coincide with the corner of an opening, BGC Fibre Cement recommends installation of a relief joint to control cracking. See Figure 7.

**FIGURE 13 //**  
TYPICAL WINDOW FRAME WEATHER PROOFING

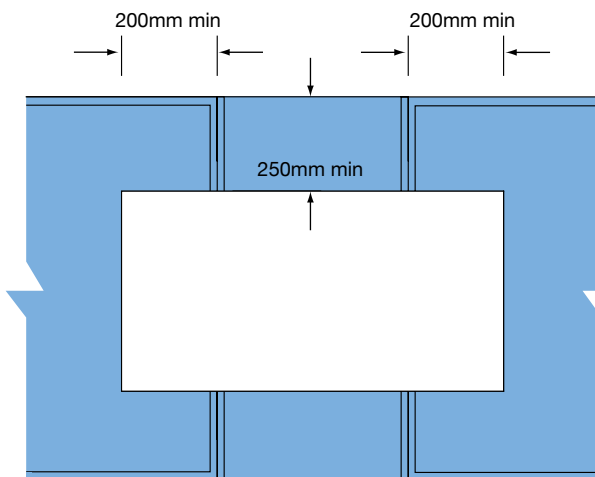

**EAVES DETAIL**

Where there is an eave on the building, the Duratex™ sheet must finish a minimum 6mm short of the eave. The 6mm gap can be filled with polyurethane sealant or a timber moulding can be fitted. Texture coating must not cover the sealant or the timber.

**FIGURE 14 //**  
TYPICAL EAVES DETAIL

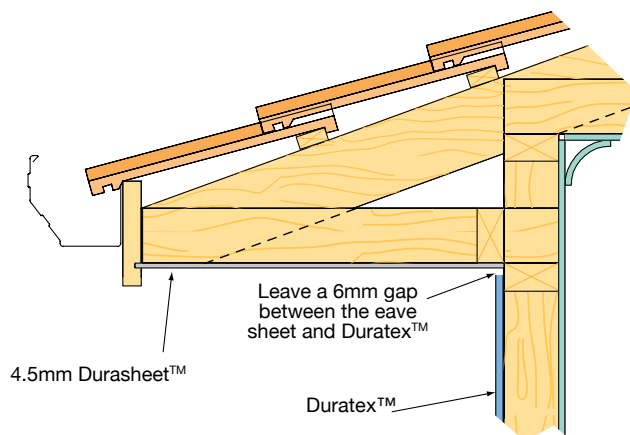



Proprietary joint and coating systems for fibre cement sheets have been developed by a number of coating manufacturers. The jointing and coating system must be applied by applicators recommended as suitable by the joint and coating manufacturer.

The selected joint and coating system must be applied to dry, clean sheets only. Application must be completed within 3 months of the sheets being fixed on site, shorter in harsher conditions.

It is strongly recommended that dark colours be avoided as they may cause high temperature variations within the substrate, leading to excessive thermal movement.

Heavier-texture coatings are preferred over smoother finishes, as any minor surface imperfections are less likely to become apparent in critical lighting conditions.

*Note: Duratex™ is not recommended to have a paint finish*

The Duratex™ cladding system must be maintained to ensure that the system continues to prevent moisture entering the building.

Check flashing, sealant joints and coating systems annually:

- // Flashings must continue to perform their design function.
- // Rake out and replace damaged or cracked sealant.
- // Replace damaged sheets and reinstate coating system as for new work.

Coatings must be maintained in accordance with the coating manufacturer's instructions.

**FIGURE 15 //**  
TYPICAL JOINT AND COATING DETAIL

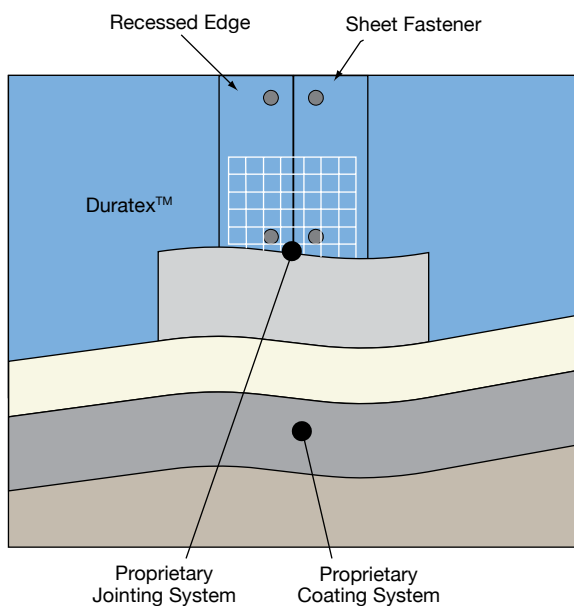

## BRACING

7.5mm Duratex™ can be used to provide bracing to resist racking loads due to wind loadings when installed vertically.

Where 7.5mm Duratex™ is used to provide bracing on timber dwellings, the Australian Standard for “Residential timber-framed construction” must be adhered to:

AS1684.2-1999 (Non-Cyclonic areas)  
AS1684.3-1999 (Cyclonic areas)

Racking forces due to wind loading shall be calculated as per these Australian Standards.

For bracing data on other construction methods and applications, contact your BGC Fibre Cement Sales Office.

## NOMINAL WALL BRACING

Up to 50% of the total bracing requirements can be supplied by 7.5mm Duratex™ sheeting installed normally. To be eligible for inclusion in calculations as nominal wall bracing:

- // The minimum length of each nominal bracing panel shall be 450mm.
- // Nominal bracing shall be distributed evenly throughout the building.

The bracing capacity for nominal bracing is given in the following table:

### NOMINAL SHEET BRACING WALLS

METHOD	BRACING CAPACITY (KNm)
Sheeted one side only	0.45
Sheeted two sides	0.75

**FIGURE 16 //**  
**DURATEX™ BRACING CAPACITY USING TIE DOWN BOLTS**

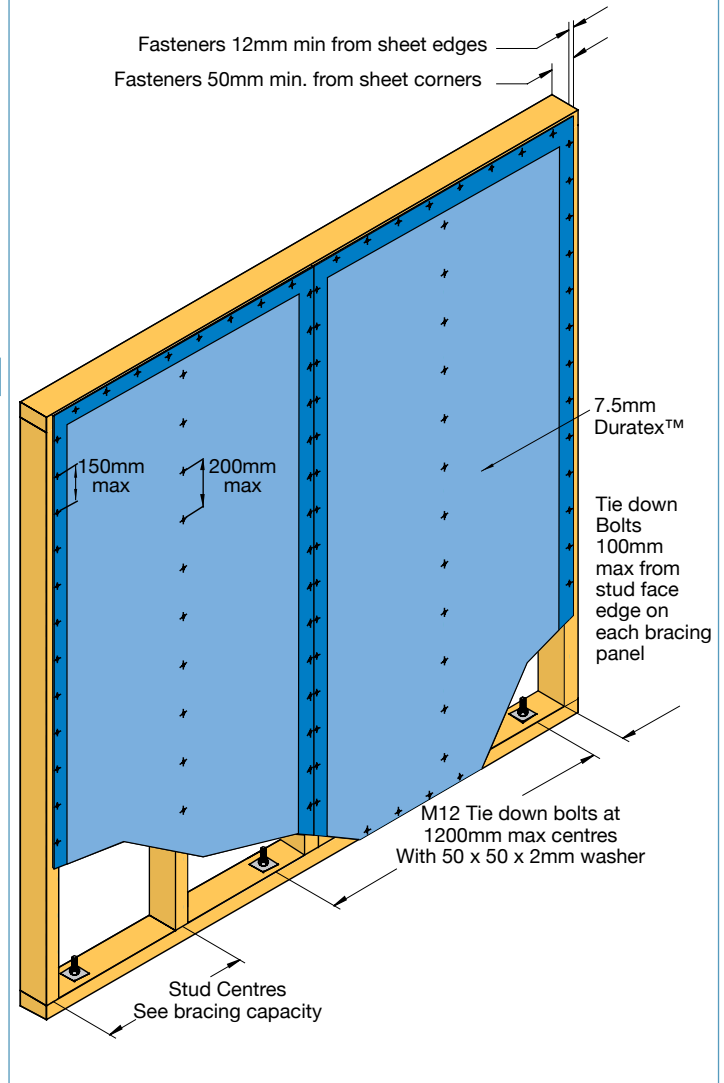

## FASTENER SPACING

When using tie down bolts, fasteners are to be fixed at 150mm max around sheet perimeter and 200mm max in the body of the sheet.

STUD CENTRE (mm)	CLADDING	BRACING CAPACITY (k/N/m) ULS*
600	One Face Only	3.6
450	One Face Only	3.75

\*Ultimate Limit State design.

These results are from testing on JD5 Grade timber. If hardwood frames (JD2) are used, the ULS will increase by 12.5%.

Permissible Stress Design (PSD) =  $\frac{\text{Ultimate Limit State (ULS)}}{1.5}$

## BRACING

Figure 17 gives the design bracing capacity for panels secured with anchor rods. This table can be considered to be an addition to Table 8.18, AS1684.2 - 1999/AS1684.3 - 1999.

**FIGURE 17 //**  
DURATEX™ BRACING CAPACITY USING ANCHOR RODS

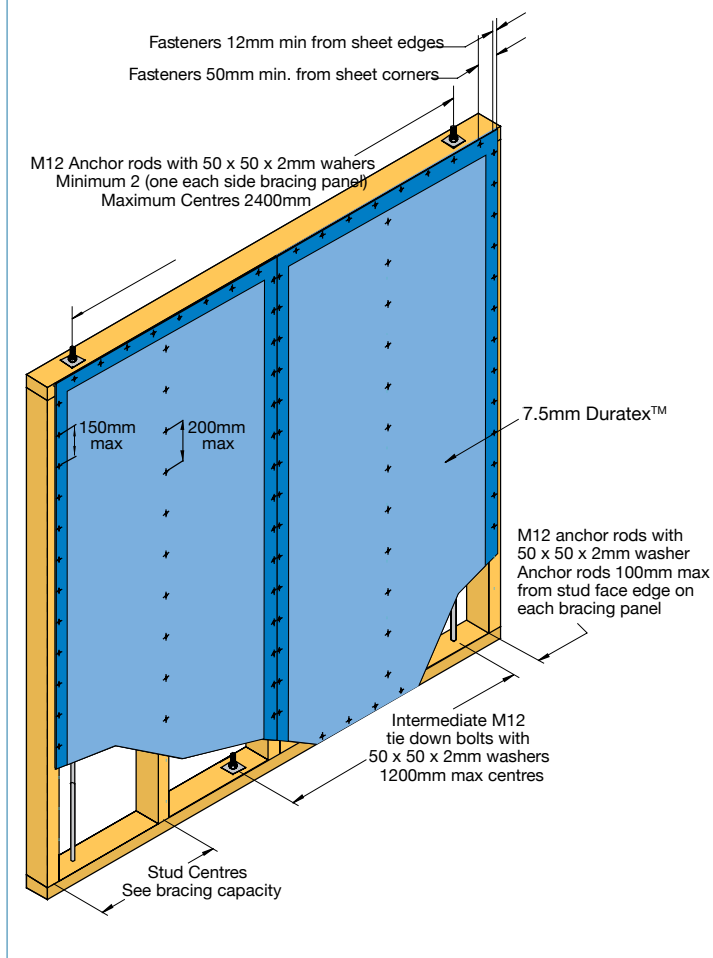

## FASTENER SPACING

When using anchor rods, fasteners are to be fixed at 150mm max around sheet perimeter and 200mm max in the body of the sheet.

STUD CENTRE (mm)	CLADDING	BRACING CAPACITY (k/N/m) ULS*
600	One Face Only	5.1
450	One Face Only	5.3+

\*Ultimate Limit State design.

These results are from testing on JD5 Grade timber. If hardwood frames (JD2) are used, the ULS will increase by 12.5%.

Permissible Stress Design (PSD) =  $\frac{\text{Ultimate Limit State (ULS)}}{1.5}$

+Calculated through interpolation.

## PANELS HEIGHT GREATER THAN 2700mm

The bracing capabilities, Figure 16 and 17 are applicable to a maximum panel height of 2700mm.

For panel heights greater than 2700mm the bracing capacity shall be reduced using the panel height multiplier given in the following table:

BRACING CAPACITY - PANEL HEIGHT MULTIPLIER

WALL HEIGHT (mm)	MULTIPLIER
3000	0.90
3300	0.80
3600	0.75
3900	0.70
4200	0.64

## PANEL LENGTH LESS THAN 900MM

The bracing capabilities, Figures 16 and 17 are applicable to a minimum panel length of 900mm. Effective bracing is achievable with panel lengths down to 450mm. Reduce the bracing capacity for panels between 450mm and 900mm long, using panel height multiplier given in the following table:

BRACING CAPACITY - PANEL HEIGHT MULTIPLIER

WALL HEIGHT (mm)	MULTIPLIER
850	0.92
800	0.83
750	0.75
700	0.66
650	0.58
600	0.50
550	0.42
500	0.33
450	0.25

## THERMAL BREAK DETAILS

Thermal breaks are required for steel framed habitable buildings. Careful consideration of thermal heat transfer and the position of thermal breaks need to be addressed by the architects, engineers and building designers. Thermal breaks should be installed between the lightweight steel CFS stud and/or top hat sections and the Duratex™ cladding. Non-enclosing wall elements may not require thermal bridging, except where the possibility of high thermal heat transfer exists through to the main structural steel element of the building.



# DURATEX™ COMMERCIAL 9MM

FIBRE CEMENT BASE SHEETS



A TOUGH, DURABLE, WATERPROOF EXTERNAL CLADDING SYSTEM BGC DURATEX COMMERCIAL IS DESIGNED SPECIFICALLY FOR USE ON INSTITUTIONAL, COMMERCIAL AND INDUSTRIAL BUILDINGS WHERE A MASONRY LOOK IS REQUIRED.

DURATEX™ COMMERCIAL IS 9MM THICK AND PROVIDES A DURABLE FAÇADE THAT SHOULD BE FINISHED WITH A HIGH BUILD COATING SYSTEM WHICH WILL ENSURE A TROUBLE FREE LIFE OF THE FAÇADE.

#### **DURATEX™ COMMERCIAL**

- // Designed for use in commercial applications
- // Cost effective lightweight construction
- // Complies with AS3959:2009 and achieves BAL40 on its own or BAL>FZ when combined with 16mm BGC Wet Area Fireboard
- // Accepts a wide range of textured coatings

## DURATEX™ 9mm IN COMMERCIAL APPLICATIONS

Duratex™ 9mm offers the designer and building owner a masonry look solution for institutional, commercial and industrial buildings.

Duratex™ clad walls up to 6m long and 1.2m, 3m or 4.2m high, can be constructed using a standard technique flush jointing system, supplied by the same manufacturer of the high build coating system.

For a long trouble free service life of Duratex™, BGC Fibre Cement recommends that use of a high build coating system over Duratex™ such as Armawall, Acratex or Garnosite.

### DESIGN

Fascias are generally 1.2m high, with the sheets laid and fixed horizontally. The Fascias and Facades higher than 1.2m are fixed vertically.

Duratex™ 9mm sheets are 1200mm wide x 2400mm and 3000mm long, with two (2) recessed long edges and one (1) short edge, are primed on both faces and all edges and are available ex-stock.

### FRAMING

Framing can be either in timber or lightweight cold-formed-section (CFS) steel Top-Hat sections or C- section studs. 45mm face-width timber and 40mm face-width Cee stud framing is typically used in smaller framed building or infill panels, up to 3.0m high.

For larger facades, up to 4.2m high, 75mm x 35mm x 0.75mm Top-Hat sections, fixed to structural CFS girts, are used.

Top-Hat and stud spacing is set at 600mm maximum for low wind speed areas, up to 1.5kPa wind pressure, and 400mm maximum spacing for high wind pressure areas, up to 2.5kPa; dependent on girt spacing. Confirm Top-Hat spacing and spans with manufacturer prior to use.

Timber and CFS stud framing must have a mid-point row of noggins for frames above 2.4m high, and where the facade exceeds 1.2m high, the sheets are to be set out vertically.

Design of supporting frame work is critical to the performance of Duratex™ 9mm. Ensure framework is suitable for imposed loads: Wind loads etc.

Similarly ensure frame work caters for thermal movement (expansion and contraction) with appropriately positioned control joints.

Decrease control joint centres to 4800mm in extreme applications. Ensure building control joints are expressed through the Duratex™ with correctly positioning control joints.

### FIXING

Duratex™ 9mm sheets are fixed to the support framing at 200mm maximum centres along the sheet edges and over intermediate supports.

Fixing must be at 12mm minimum from the sheet edges and 75mm minimum from the corners.

FIGURE 18 //  
DURATEX™ 9mm FIXING DETAIL

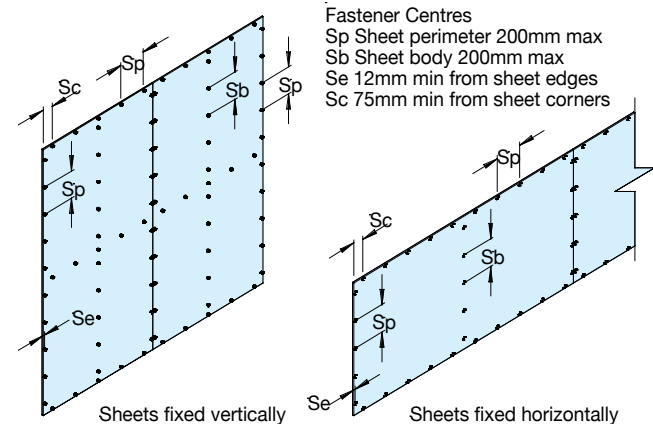

Sheets fixed to lightweight CFS steel Top Hat and Stud supports are placed over 6mm x 50mm thermal bridging tape, such as Norton V768 or UNISIL 3208, or equivalent.

Countersunk, Self Embedding Winged, self drilling Screws 32mm long complying with AS3655 are to be used when fixing to lightweight CFS steel support framing. Sheets are to be pre-drilled if Winged Screws are not used.

FIGURE 19 //  
DURATEX™ 9mm SCREW FIXED SET JOINT DETAIL

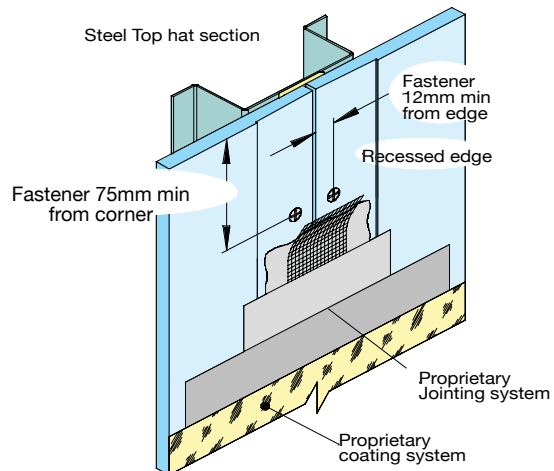

Fixing to timber framing is effected using 40 x 2.8mm Galvanised Fibre Cement Nails, driven flush to the sheet surface.

## CONTROL JOINTS

Vertical and horizontal control joints are required where the wall length exceeds 4800mm long and height exceeds 3.0m and as required by the building design, articulation and framing layout, in accordance with the design consultants dealing.

Construction and control joints allow for relative movements between the building mainframes, subframes and cladding systems, due to building settlement, thermal movements and other forces. Flexible/slip joints allow for these movements and consist of a sealed joint, bond breaker tape and fixings.

Where CFS Top Hat sections are used, 10mm construction control joints are affected over two separate supporting Top Hats, as shown in the diagram below.

FIGURE 20 //

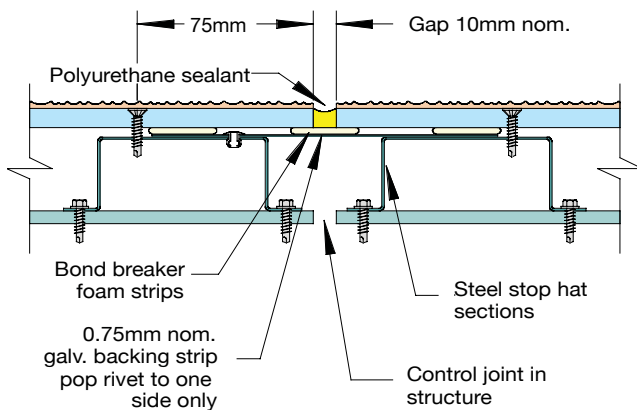

Module slip/control joints over CFS Top Hat framing must have a 10mm gap between each adjacent module of Duratex™ panels, as shown in the diagram below.

FIGURE 21 //

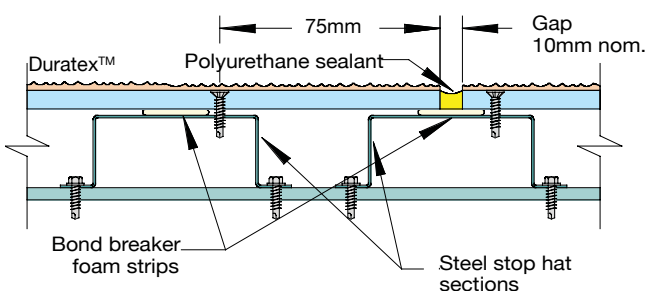

Horizontal joints are similar to the vertical jointing systems and may be expressed or have architectural details applied.

Where openings occur, such as doors, windows, signage apertures and the like, relief joints should be used to prevent the possibility of system failure due to induced stresses. These joints are similar to the module slip/control joint, with a nominal 3mm gap between sheets, in line with the opening's vertical edge.

## WARRANTY

We warrant that our products are free from defects caused by faulty manufacture or materials for a period of 15 years from the date of purchase. If you acquire any defective products, we will repair or replace them, supply equivalent replacement products or refund the purchase price within 30 days of receiving a valid claim subject to product inspection and confirmation of the existence of a defect by BGC. We will bear the cost of any such repair, replacement or refund.

### This warranty is given by:

BGC Fibre Cement Pty Ltd  
121 Bannister Rd Canning Vale WA 6155  
Phone 08 9334 4900 Fax 08 9334 4749

To claim under this warranty, you must provide proof of purchase as a consumer and make a written claim (including any costs of claiming) to us at the address specified above within 30 days after the defect was reasonably apparent, or if the defect was reasonably apparent prior to installation, the claim must be made prior to installation. You may not claim under this warranty for loss or damage caused by:

- faulty or incorrect installation by non-BGC installers (BGC's installation procedures are at [www.bgcinnovadesign.com.au](http://www.bgcinnovadesign.com.au));
- failure to comply with the Building Code of Australia or any applicable legislation, regulations approvals and standards;
- products not made or supplied by BGC;
- abnormal use of the product; or
- normal wear and tear.

The benefits available under this warranty are in addition to other rights and remedies of the consumer under the law. Our goods come with guarantees that cannot be excluded under the Australian Consumer Law. You are entitled to a replacement or refund for a major failure and for compensation for any other reasonably foreseeable loss or damage.

You are also entitled to have the goods repaired or replaced if the goods fail to be of acceptable quality and the failure does not amount to a major failure.



Duratex™ is eminently suited for both bushfire and boundary wall applications in residential and multi residential buildings.

Duratex™ 7.5mm can be used as a stand alone product to achieve up to BAL29 and BGC Duratex™ 9.0mm can be used as a stand alone product to achieve up to BAL 40 when fixed direct to frame as per the fixing instructions in this manual.

Duratex™ when used in conjunction with BGC 16mm Wet Area Fireboard will comply with the requirements of AS3959:2009 and AS1530.4 to achieve BAL FZ>10 as well as 60 minute and 90 minute boundary wall systems.

Bushfire AS3959:2009 applications:

AS3959:2009 sets out a series of Bushfire threat levels to buildings described as BAL (Bushfire Attack Levels) as follows: BAL-Low, BAL-12.5, BAL-19, BAL-29, BAL-40 or BAL-FZ (Flamezone).

Duratex™ 7.5mm may be used to achieve a BAL29 or BAL FZ>10 when used in conjunction with 16mm Wet Area Fireboard. – Duratex™ 9.0mm may be used to achieve a BAL40 or BAL FZ>10 when used in conjunction with 16mm Wet Area Fireboard.

Duratex™ in conjunction with BGC 16mm Wet Area Fireboard can achieve both 60/60/60 and 90/90/90 FRL fire ratings from the outside as required by the BCA.

Where an exterior wall is required to achieve 60/60/60 FRL (Fire Resistance Level) from the outside, 1 layer of 16mm BGC Wet Area Fireboard installed with Duratex™ over the Wet Area Fireboard will meet minimum BCA requirements. Similarly 2 layers of 16mm BGC Wet Area Fireboard used in conjunction with Duratex™ will achieve 90/90/90 from the outside.

*Note: All external walls must have sarking beneath the Duratex™. No adhesives are to be used when installing Wet Area Fireboard and the Duratex™. Nails or screws must be used.*

For fixing details of the BGC Wet Area Fireboard refer to the BGC Fire and Acoustic Guide.

For more information please contact your nearest BGC Fibre Cement office.

**FIGURE 22 //**  
BGC ONE SIDED FRL TEST JULY 2009 LOAD BEARING

Sarking  
BGC 16mm Wet Area Fireboard  
Duratex™

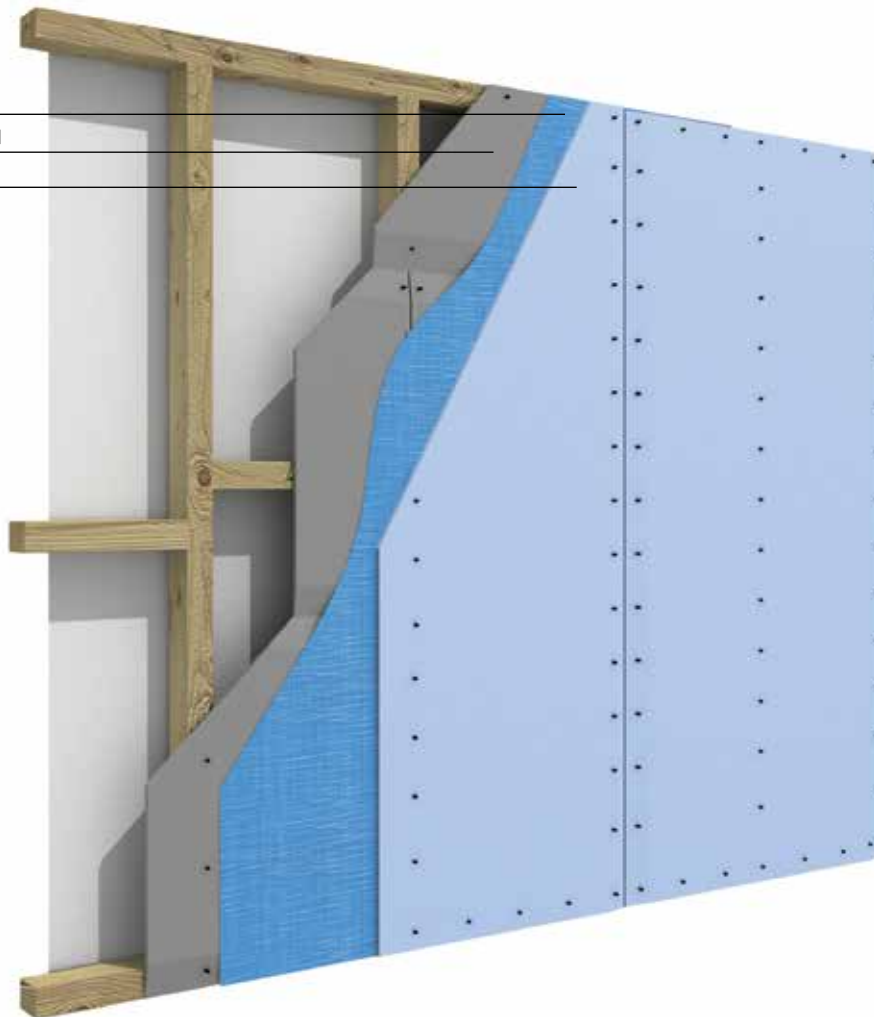



TO CONTACT  
YOUR NEAREST  
BGC STOCKIST,  
PLEASE CALL:

#### ADELAIDE

71 FROST ROAD  
SALISBURY SOUTH  
SOUTH AUSTRALIA 5106  
TELEPHONE 08 8250 4962  
FACSIMILE 08 8258 2612

#### BRISBANE

53 ARGON STREET  
QUEENSLAND 4300  
TELEPHONE 07 3271 1711  
FACSIMILE 07 3271 1733

#### MELBOURNE

200 MAIDSTONE STREET  
ALTONA  
VICTORIA 3018  
TELEPHONE 03 9392 9444  
FACSIMILE 03 9392 9404

#### PERTH

121 BANNISTER ROAD  
CANNING VALE  
WESTERN AUSTRALIA 6155  
TELEPHONE 08 9334 4900  
FACSIMILE 08 9334 4749

#### SYDNEY

233 MILPERRA ROAD  
BANKSTOWN  
NEW SOUTH WALES 2200  
TELEPHONE 02 9771 9660  
FACSIMILE 02 9771 9870

#### TECHNICAL HELP LINE

1300 652 242

[BGCINNOVADESIGN.COM.AU](http://BGCINNOVADESIGN.COM.AU)

## BGC FIBRE CEMENT IS A PROUD AUSTRALIAN OWNED MANUFACTURER OF FIBRE CEMENT PRODUCTS.

## BGC FIBRE CEMENT PROVIDES BUILDERS, DEVELOPERS AND ARCHITECTS WITH A RANGE OF DESIGN ALTERNATIVES AND INNOVATIVE PRODUCTS, SUCH AS:

### EXTERIOR PRODUCTS AND APPLICATIONS INNOVA RANGE OF PRODUCTS

**DURACOM™** / A compressed fibre cement facade system.

**DURAFLOOR™** / Is the ultimate flooring product that can be used in both interior and exterior applications.

**DURAGRID™ RESIDENTIAL & DURAGRID™ LIGHT COMMERCIAL** / A lightweight facade giving a modern and durable finish.

**DURAGROOVE™** / A vertically grooved exterior facade panel.

**DURASCAPE™** / A lightweight exterior facade base sheet with a subtle vertical shadow line.

**NULINE™ PLUS** / A weatherboard style cladding system.

**STONESHEET™** / Purpose designed substrate for stone tile facade.

**STRATUM™** / Is a range of plank products, each of which can be used as stand alone products or used together to create a striking exterior cladding solution.

**STRATUM™ ERA** / A traditional, yet contemporary as it is flat weatherboard.

### INTERIOR PRODUCTS AND APPLICATIONS BGC FIBRE CEMENT RANGE OF PRODUCTS

**DURALUX™ PLUS** / An interior lining board suitable for ceilings and soffits.

**DURALINER™ PLUS** / An interior lining board this is the perfect substrate for tiles and is ideal for wet areas.

**CERAMIC TILE UNDERLAY** / A substrate for ceramic and slate floor tiles.

**VINYL CORK FLOOR COVERINGS** /  
A substrate for vinyl floors.

### EXTERIOR PRODUCTS AND APPLICATIONS BGC FIBRE CEMENT RANGE OF PRODUCTS

**DURASHEET™** / Ideal for the cladding of gables and lining of eaves. Can also be used on commercial soffits and cladding on non impact areas.

**DURAPLANK™** / Available in Smooth, Woodgrain and Rusticated finishes, Duraplank™ is ideal for exterior cladding of upper storey conversions or ground level extensions.

**DURATEX™** / A base sheet used for textured coatings on exterior wall applications.

**DURALATTICE™** / Square or diamond patterned lattice, suitable for screens, pergolas and fences.

**COMPRESSED** / Used for domestic, commercial sheet for wet areas, flooring, partitions, exterior decking, fascia and facade cladding.

**DURALUX™ PLUS** / Suitable for exterior applications where it will be sheltered from direct weather.



Build it better with BGC

**BGC**

Fibre Cement

**Safe working practices** - Please wear a P1 or P2 mask and safety goggles (approved to AS/NZW1337 standards) whilst cutting or installing Duratex™. Duratex™ can be safely handled during unloading or stacking without the use of these precautions.

**Cleaning up** - Always wet down your work area when cutting Duratex™, to ensure that dust is managed. Dispose of any vacuumed dust with care and using containment procedures.